

Multi-Quick
MQ 150 komplett

Spannkraft: **bis 40 kN**

**Einsatzgebiete vorzugsweise:
Zerspanungstechnik**

- patentiert in der EU
- 2-fach stufenloser Verstellbereich
- große Spannkraften bei kleinem Anziehdrehmoment
- große horizontale und vertikale Verstellbarkeit

- **Material: legierter Edelstahl, gehärtet**
- **Spannhebel: gesenkgeschmiedet**

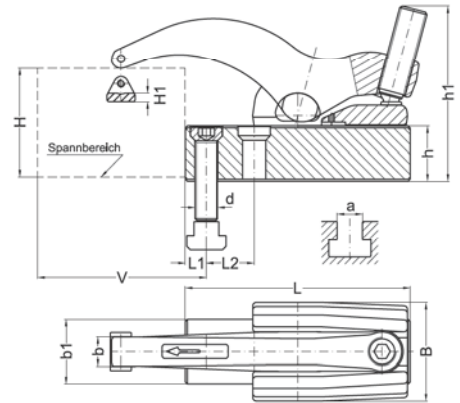

			für T-Nutenführungen		für Gewindebohrungen												
H	d	a	Best.-Nr.		Best.-Nr.		V	L	L1	L2	B	b	b1	h	h1	H1	kN
5-80 L	-	-	150-080-13		-		10-126	140	12	28	56	18	38	31	105	5	30
	M10	12	150-080-1012		150-080-10												
	M12	14	150-080-1214		150-080-12												
	M12	16	150-080-1216		-												
	M12	18	150-080-1218		-												
	-	-	150-080-17		-												
M16	18	150-080-1618		150-080-16													
6-92 L	-	-	150-092-17		-		10-150	160	15	34	70	21	46	39	126	6	40
	M14	16	150-092-1416		150-092-14												
	M16	18	150-092-1618		150-092-16												
	M16	20	150-092-1620		-												
	M16	22	150-092-1622		-												
	-	-	150-092-21		-												
M20	22	150-092-2022		150-092-20													

Multi-Quick
MQ 150 Einzelteile



Aufspannleiste		Befestigungs-satz		Spannhebel mit Führungsschuh		Werkstück-schonplatte		Blattfeder mit Befestigung		Kugeldruck-schraube		Schlüssel	
Best.-Nr.		Best.-Nr.		Best.-Nr.		Best.-Nr.		Best.-Nr.		Best.-Nr.		Best.-Nr.	
150-2-140-13		-		150-5-080-13		991-150-12-1		360-100-113		310-16-060		610-08	
150-2-140-1012		960-1012-48		L									
150-2-140-1214		960-1214-50											
150-2-140-1216		960-1216-50											
150-2-140-1218		960-1218-58											
150-2-140-17		-											
150-2-140-1618		960-1618-58											
150-2-160-17		-		150-5-092-17		991-150-16-1		360-100-117		310-20-070		610-10	
150-2-160-1416		960-1416-62		L									
150-2-160-1618		960-1618-65											
150-2-160-1620		960-1620-65											
150-2-160-1622		960-1622-70											
150-2-160-21		-											
150-2-160-2022		960-2022-75											
												610-12	