

Multi-Quick
MQ 100 Baugruppe 8 komplett

Einsatzgebiete vorzugsweise:
leichte Zerspanungstechnik

- Markenschutz Multi-Quick
- 2-fach stufenloser Verstellbereich
- große Spannkraften bei kleinem Anziehdrehmoment
- große horizontale Verstellbarkeit durch integrierte Lagerplatte

Spannkraft: **bis 22 kN**

- Material: legierter Edelstahl, gehärtet
- Spannhebel/Spansschuh: gesenkgeschmiedet

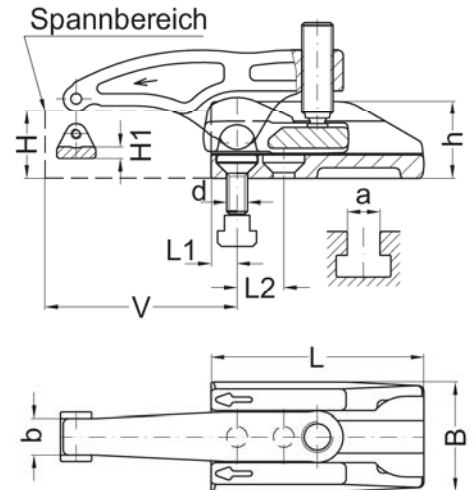

			für T-Nutenführungen		für Gewindebohrungen										
H	d	a	Best.-Nr.		Best.-Nr.		V	L	L1	L2	B	b	h	H1	kN
5-38 K	-	-	100-038-13		-		15-50	65	10	-	45	14	30	4	22
	M06	8	100-038-0608		100-038-06										
	M08	10	100-038-0810		100-038-08										
	M08	12	100-038-0812		-										
	M10	12	100-038-1012		100-038-10										
M12	14	100-038-1214		100-038-12											
5-45 L	-	-	100-045-13		-		15-62	82	10	18	45	14	30	4	22
	M06	8	100-045-0608		100-045-06										
	M08	10	100-045-0810		100-045-08										
	M08	12	100-045-0812		-										
	M10	12	100-045-1012		100-045-10										
M12	14	100-045-1214		100-045-12											

Multi-Quick
MQ 100 Baugruppe 8 Einzelteile



Spannschuh		Befestigungssatz		Spannhebel mit Lagerplatte		Werkstückschonplatte		Blattfeder mit Befestigung		Kugeldruckschraube		Schlüssel	
Best.-Nr.		Best.-Nr.		Best.-Nr.		Best.-Nr.		Best.-Nr.		Best.-Nr.		Best.-Nr.	
100-2-065-13		-		220-5-033-09		991-150-08-1		360-100-09		310-12-036		610-06	
100-2-065-0608		960-0608-24-8		K									
100-2-065-0810		960-0810-26-8											
100-2-065-0812		960-0812-26-8											
100-2-065-1012		960-1012-27-8											
100-2-065-1214		960-1214-30-8											
100-2-082-13		-		220-5-040-09		991-150-08-1		360-100-09		310-12-040		610-06	
100-2-082-0608		960-0608-24-8		L									
100-2-082-0810		960-0810-26-8											
100-2-082-0812		960-0812-26-8											
100-2-082-1012		960-1012-27-8											
100-2-082-1214		960-1214-30-8											